

# Drum Pump Motors | Hazardous Duty

## SP-400 SERIES

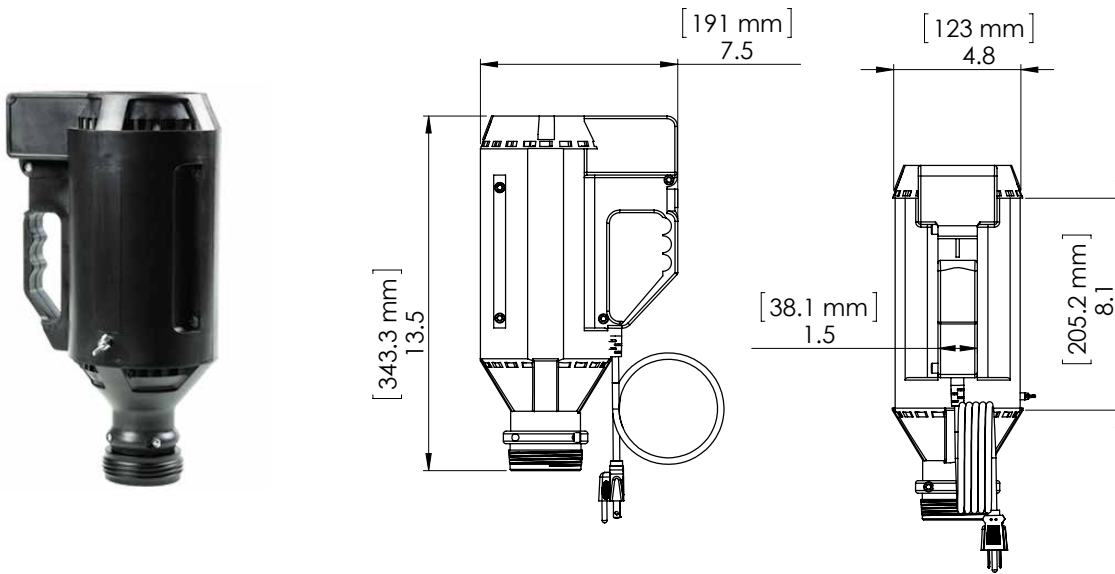

### Technical Specifications

MODEL	ENCLOSURE	CERTIFICATION	POWER	WATT	V.S.D.	SHIPPING WT
SP-410EX	Explosion Proof	SP®	110-120V/1/50-60Hz	230	No	17.0 lbs (7,7 kg)
SP-420EX	Explosion Proof	ATEX CE	220-240V/1/50-60Hz	600	No	17.0 lbs (7,7 kg)

**ATEX Certification:** II 2G Ex d IIA T4 FTZU 12 ATEX 0225X

**NOTE:** V.S.D. = Variable Speed Drive    **NOTE:** Explosion proof motor regulations require that motors be returned to the manufacturer for repair.

**⚠ WARNING:** Pumping of flammables or combustible liquids can generate a static electric discharge, causing fire or explosion resulting in injury or death. Read and understand operating instructions before starting this unit. Follow all federal, state and local safety codes including NFPA 30 - NFPA77. Prior to connecting to air supply, install bond and ground wires and check continuity of each wire. A meter reading of one ohm or less is required for safe liquid transfer. Use only metallic drum, receiving vessel and metallic pump when pumping flammables. Air motors are not recognized under any current Underwriter's Laboratory listing program. Consult a qualified engineer for suitability for use in a hazardous area or on flammables.